

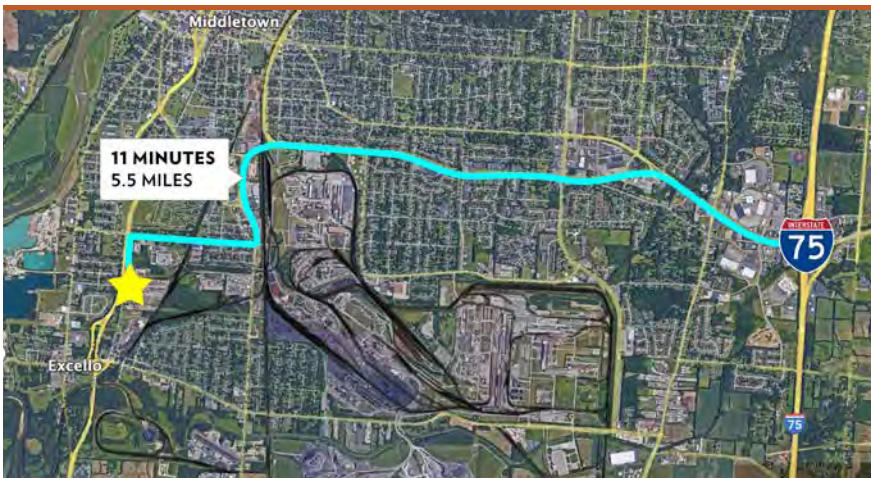

2601 SOUTH VERITY PARKWAY, MIDDLETOWN, OHIO 45044—BLDG 30 AVAILABLE FOR LEASE



PROPERTY HIGHLIGHTS

 **8,840 SqFt**

- Located in City of Middletown 5.5 miles from I-75
- Available within 90 days' notice
- Additional docks/drive-in's To Suit
- Crane capacity expandable
- Outdoor storage and expansion available
- Designated HUB and Enterprise Zone
- \$5.95/SqFt NNN + \$0.76/SqFt OpEx/CAM
- \$4,943/month gross

INFO@SQFTCOMMERCIAL.COM | (513) 843-1600 | SQFTCOMMERCIAL.COM

MIDD CITIES INDUSTRIAL PARK

BUILDING 30

PROPERTY DETAILS

Total SqFt:	8,840
Office SqFt:	4,540
Length:	147' 4"
Width:	60'
Eave Height:	24'
Crane Hook Height:	17' 4"
Drive-in door:	12'x14'
Heat:	Gas/Air Rotation Systems
Floor Depth:	Varies 8"-12"
Crane Service:	5-Ton
Outdoor Storage:	Available

FLOOR PLAN

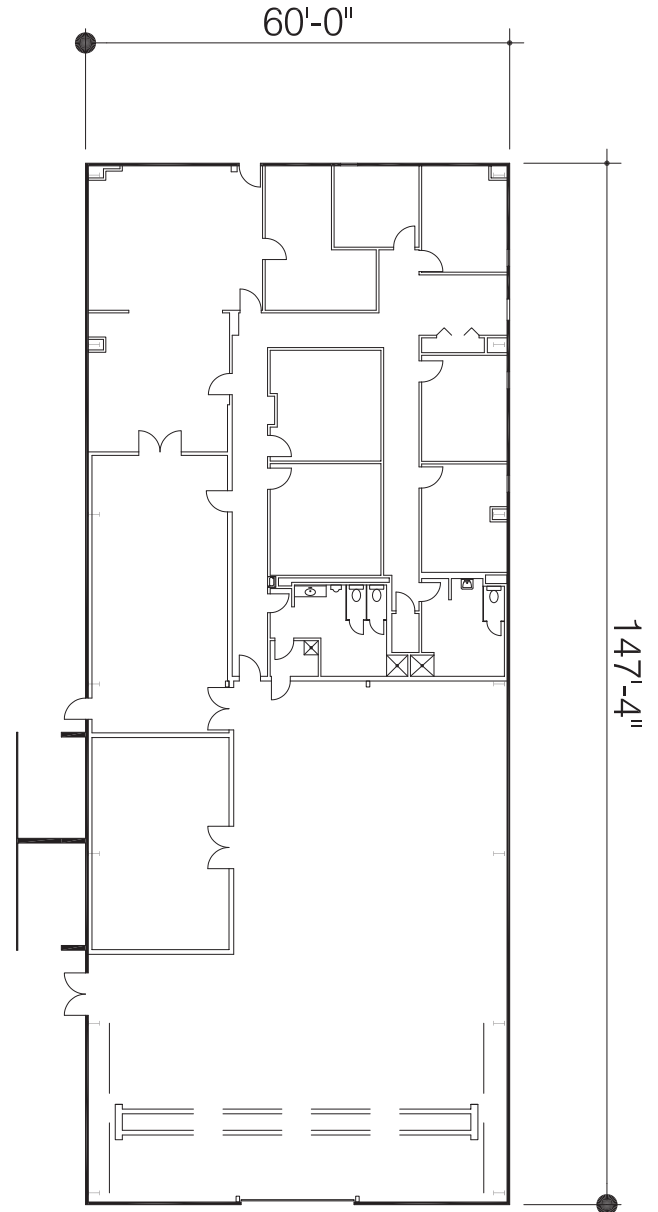

CRANE SERVICE

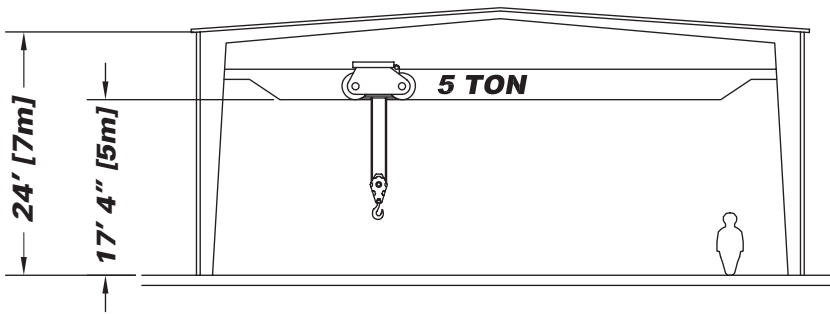

INFO@SQFTCOMMERCIAL.COM | (513) 843-1600 | SQFTCOMMERCIAL.COM



Rod MacEachen
 (513) 675-5764
Rod@SqFtCommercial.com

Roddy MacEachen, SIOR
 (513) 739-3985
Roddy@SqFtCommercial.com

Jared Wagoner
 (812) 890-1768
Jared@SqFtCommercial.com

BROCHURE DESIGNED BY NICK TEDESCHI. CONTACT NICK AT HELLO@DESIGNEDBYNICK.COM OR 781-752-9699 TO DISCUSS YOUR MARKETING NEEDS.

MIDD CITIES INDUSTRIAL PARK

BUILDING 30

SITE MAP

BUILDING 30 - 8,840 SQFT

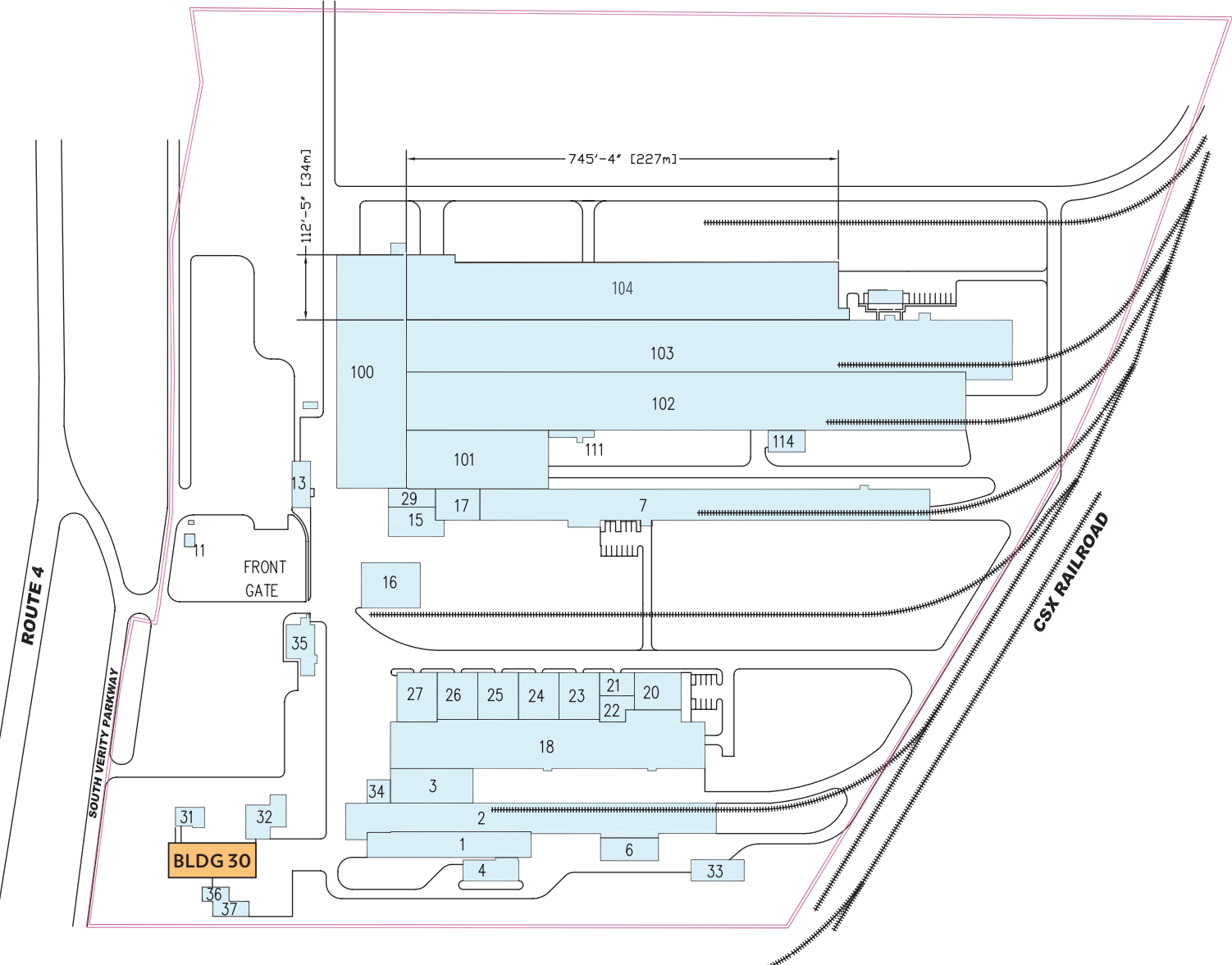

INFO@SQFTCOMMERCIAL.COM | (513) 843-1600 | SQFTCOMMERCIAL.COM



Rod MacEachen
 (513) 675-5764
 Rod@SqFtCommercial.com

Roddy MacEachen, SIOR
 (513) 739-3985
 Roddy@SqFtCommercial.com

Jared Wagoner
 (812) 890-1768
 Jared@SqFtCommercial.com

BROCHURE DESIGNED BY NICK TEDESCHI. CONTACT NICK AT HELLO@DESIGNEDBYNICK.COM OR 781-752-9699 TO DISCUSS YOUR MARKETING NEEDS.

© 2021 SqFt Commercial LLC. All rights reserved. No warranty or representation, express or implied, is made to the accuracy or completeness of the information contained herein, and same is submitted subject to errors, omissions, change of price, rental or other conditions, withdrawal without notice, and to any special listing conditions imposed by the property owner(s). As applicable, we make no representation as to the condition of the property (or properties) in question. This information has been obtained from sources believed reliable, but has not been verified for accuracy or completeness. You should conduct a careful, independent investigation of the property and verify all information. Any reliance on this information is solely at your own risk. SqFt Commercial and the SqFt Commercial logo are service marks of SqFt Commercial, Inc. All other marks displayed on this document are the property of their respective owners. Photos herein are the property of their respective owners. Use of these images without the express written consent of the owner is prohibited.