



513-271-0624
hjackson@middcities.com
www.middcities.com

Strategically
located
five miles from
I-75 between
Cincinnati and
Dayton, Ohio

Midd Cities Industrial Park—Building 101

2601 South Verity Parkway, Middletown, Ohio 45044



Building 101 Features

- Available:** 25,000 SF
- Length:** 246'
- Width:** 100'
- Eave Height:** 36'
- Clear Height:** 35'
- Crane Hook Height:** 22'
- Heat:** Gas/Air Rotation Systems
- Floor Depth:** Varies 8"-12"
- 1 Drive-in Door**
- Offices are Build-to-Suit:**
3,000 SF of office space is available but not included
- Crane Service:** 10-Ton
Upgradeable to 25-Ton
- CSX Rail Access Adjacent**
- Outdoor Storage Available**

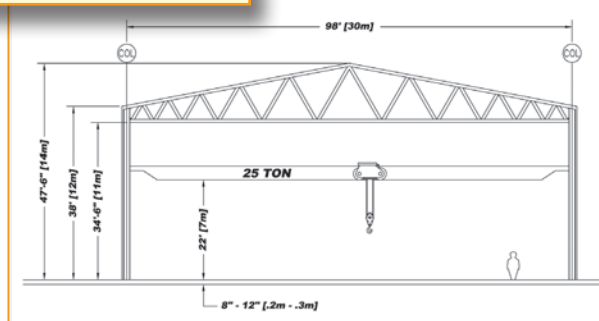
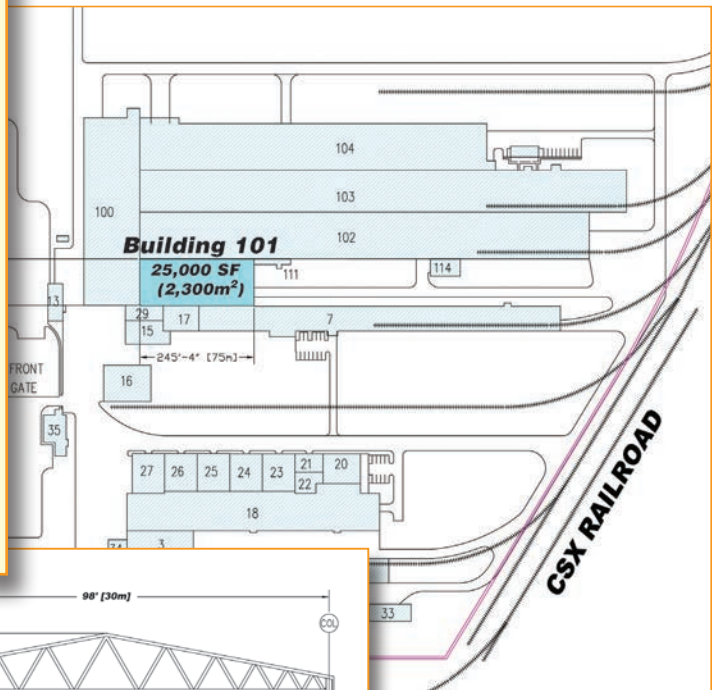

Building 101

Call Howard Jackson for more information – 513-271-0624 or hjackson@middcities.com



Midd Cities Industrial Park—Building 101

2601 South Verity Parkway, Middletown, Ohio 45044

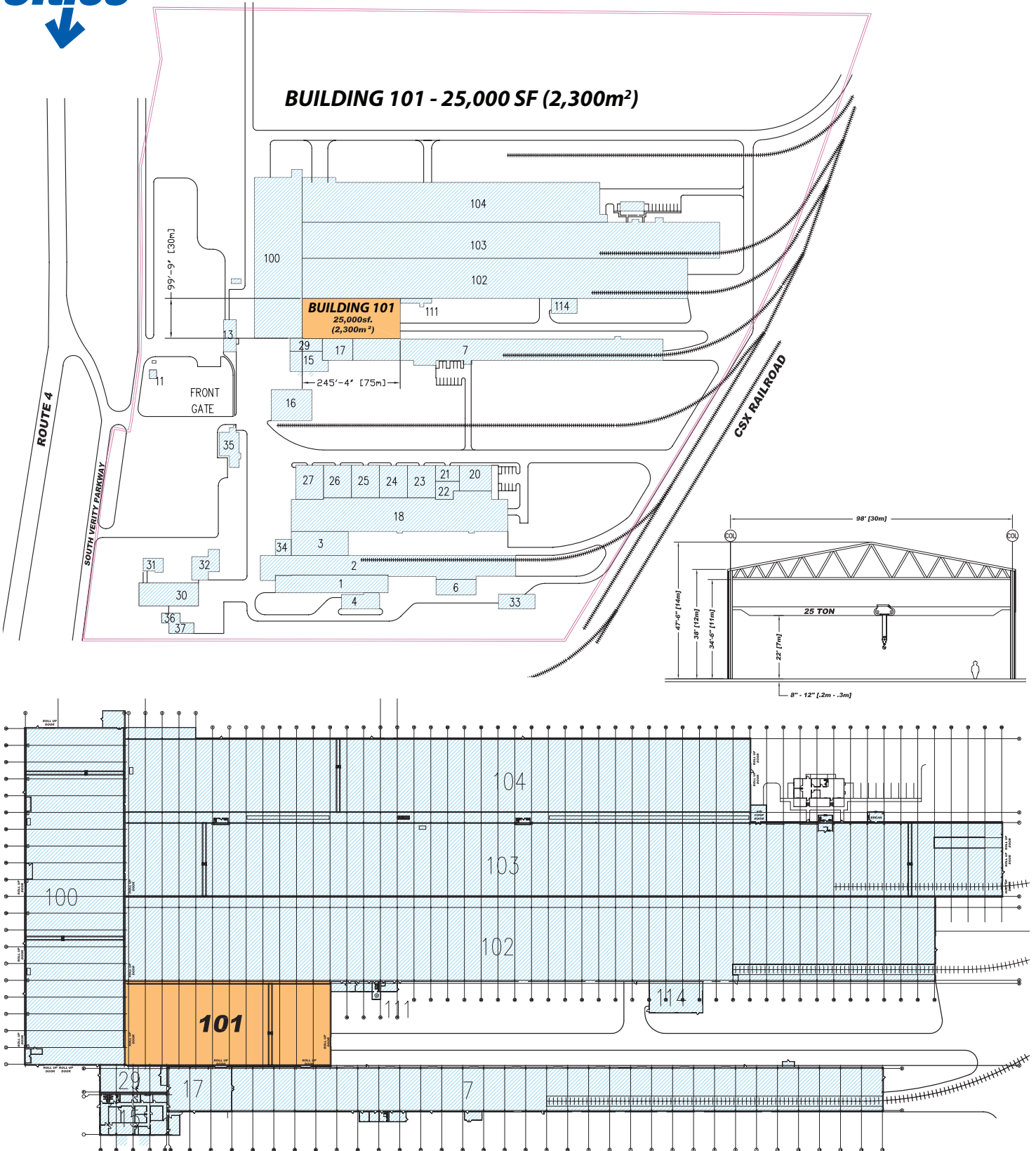



513-271-0624
hjackson@middcities.com
www.middcities.com

Strategically
located
five miles from
I-75 between
Cincinnati and
Dayton, Ohio

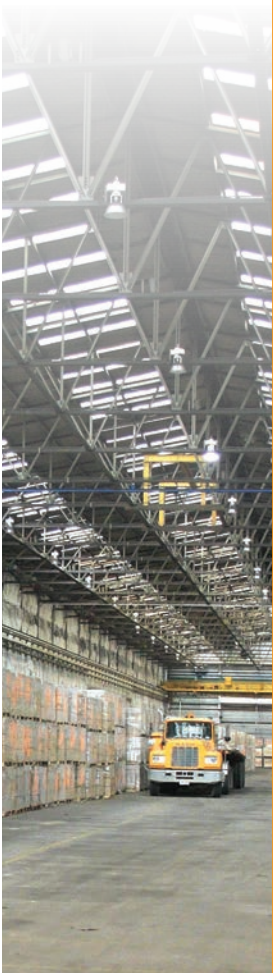

Midd Cities Industrial Park—Building 101

2601 South Verity Parkway, Middletown, Ohio 45044

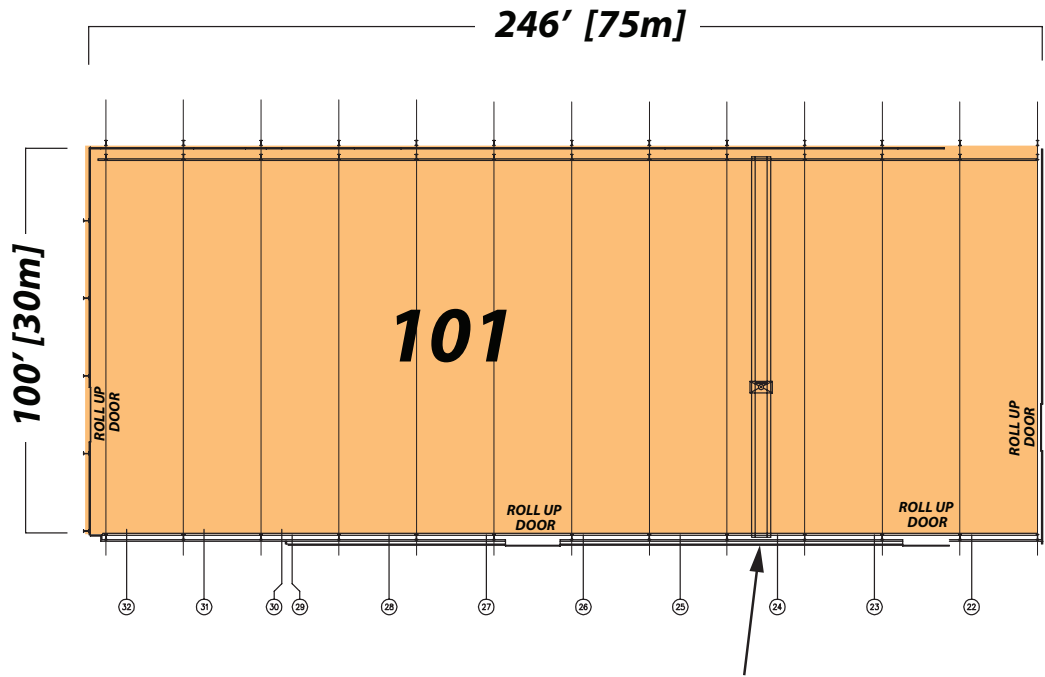

Specifications

- Length:** 246'
- Width:** 100'
- Eave Height:** 36'
- Clear Height:** 35'
- Crane Hook Height:** 22'
- Floor Depth:** Varies 8"-12"
- 1 Drive-in Door**
- Offices are Build-to-Suit:**
3,000 SF of office space is available but not included
- Crane Service:** 25-Ton

**25-ton
overhead crane**